



The cyclonic separators of the Turbix line are used for vacuuming large quantities of dust, especially fine dusts, in order to intercept and drop them down, avoiding excess deposits on the walls of the filter, that would cause its obstruction, with the consequent reduction in vacuum power and the need for frequent maintenance.

They are available in three different sizes, depending on the diameter of the line to which they are connected and of the vacuum unit.



SELECTION TABLE TURBIX MODEL

MODEL	ARTICLE	Connections IN/OUT Ø mm	Dust container capacity l
Turbix Small	3400.10	50	21
Turbix Medium	3400.11	60	40
Turbix Big	3400.12	80	70
Turbix Big XL	3400.13	100	106

MAIN FEATURES OF THE PRODUCT

1 - Great efficiency

The ability to separate dust is exceptional: in some cases its **effectiveness is more than 98% of the total quantity of vacuumed dust**. The secret is due to the particular shape of the cone, which creates a cyclonic movement of the dust with increasing speed. At the end of the cone, when the air flows into the dust bin, it slows down and allows the powder to fall to the bottom of the bin, while the clean air will continue its path towards the top of the cone, where, through the upper inlet, it will reach the vacuum unit, free of dust particles, without dirtying the filter or filling the dust bin.

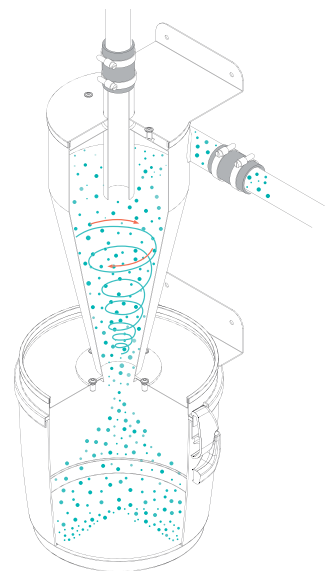

2 - Absence of filter

Turbix special separators don't contain a filter, for this reason maintenance means the dust bin emptying only.

Inside the cone of the separators the air filtration is made by cyclonic separation, without any other filtration system. It is a warranty of effectiveness and above all a considerable simplification in maintenance.

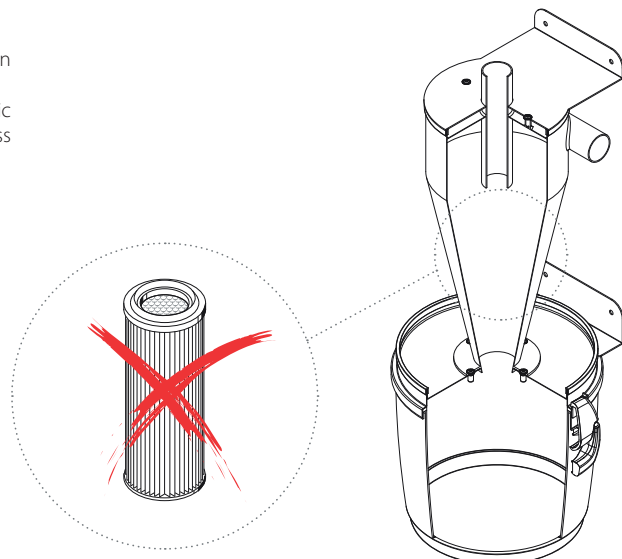

TURBIX

■ Turbix Small/Medium SECTION

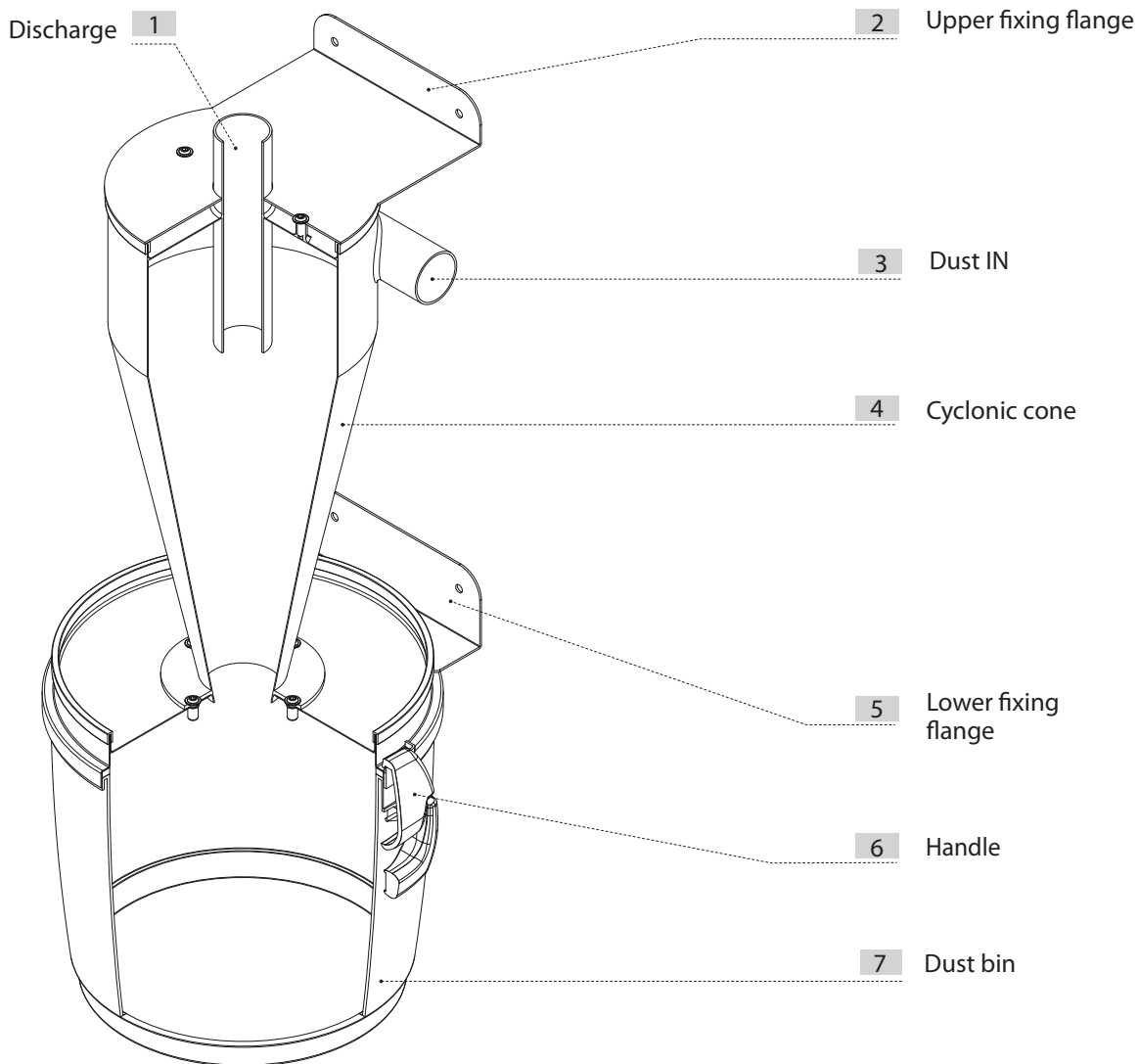

Turbix separators, with their effectiveness and simplicity, are set to revolutionise the use of central vacuum systems.

MEASUREMENT AND TECHNICAL DATA

The model should be chosen according to the number of simultaneous users connected to Turbix, the diameter of connecting pipes, the number of simultaneous users connected to the vacuum unit and the dust bin capacity of Turbix separator.

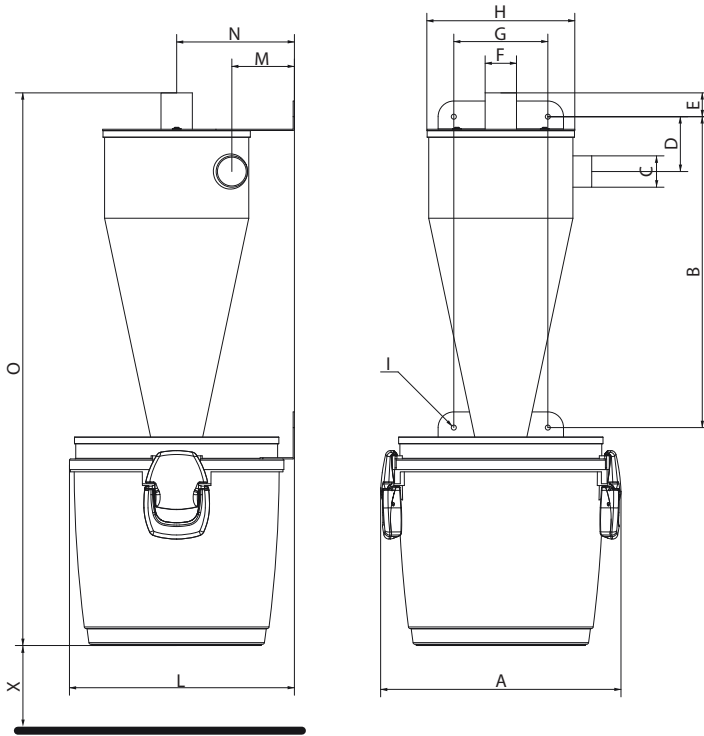

Model Article		Turbix	
		Turbix Small	Turbix Medium
		3400.10	3400.11
Dust IN/OUT	Ø mm	50	60
Dust bin capacity	l	21	40
Weight	kg	15	25
Measurement A	mm	385	452
Measurement B	mm	489	590
Measurement C	Ø mm	50	63
Measurement D	mm	98	103
Measurement E	mm	14	52
Measurement F	Ø mm	50	63
Measurement G	Ø mm	150	190
Measurement H	Ø mm	236	286
Measurement I	R mm	4	4
Measurement L	mm	360	436
Measurement M	mm	100	122
Measurement N	mm	188	228
Measurement O	mm	855	1105
Measurement X	mm	100	100

TECHNICAL FEATURES

Turbix Small and Medium dust separators are designed and produced in conformity with all current regulations and European directives, whilst taking into account functionality, power and capacity.

Main technical characteristics can be listed as follows:

- Metal cylindrical frame painted with epoxy powder
- Polypropylene dustbin (model Turbix Small capacity 21 litres)
- Metal dust bin painted with epoxy powder (model Turbix Medium capacity 40 litres)
- Possible connection from the right or from the left
- Sleeves for connection to the pipe network supplied

TURBIX

INSTALLATION TIPS

The cyclonic separators Turbix Small and Medium are connected at the end of the line that comes from the vacuum inlets before the vacuum unit (or main dust separator). The connection can be made at the end of a group of inlets, in order to make cyclonic separation only for a certain group of inlets, or it can take place just before the vacuum unit (or main dust separator), so as to collect all the vacuumed material.

FIXING THE SEPARATOR

Turbix Small and Medium cyclonic separators must be hung on the wall using the supplied bracket, which must be fixed permanently to the wall by the use of appropriate plugs, considering that the total supported weight can be considerably higher than the weight of the separator itself.

N.B. The separator must be set so that the bucket sits at a height of more than 10 cm from the ground.

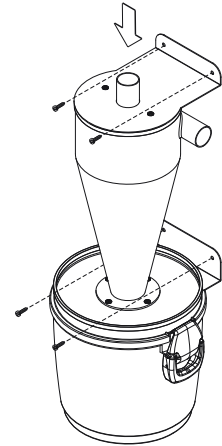

REVERSIBLE CONNECTIONS

All Turbix separators can be connected to the pipe network from the right or from the left. Transformation is easy and quick.

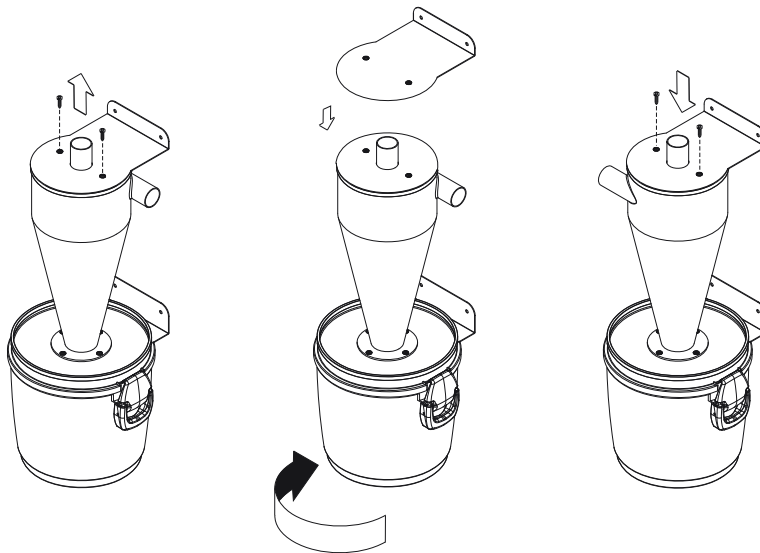

PIPE NETWORK CONNECTION

Turbix separators are supplied with connecting anti-vibration sleeves and clamps for the pipe network connection.

The separator must be connected to the pipe network before the vacuum unit, so that it can intercept the dust that arrives from the vacuum inlets, before it reaches the vacuum unit.

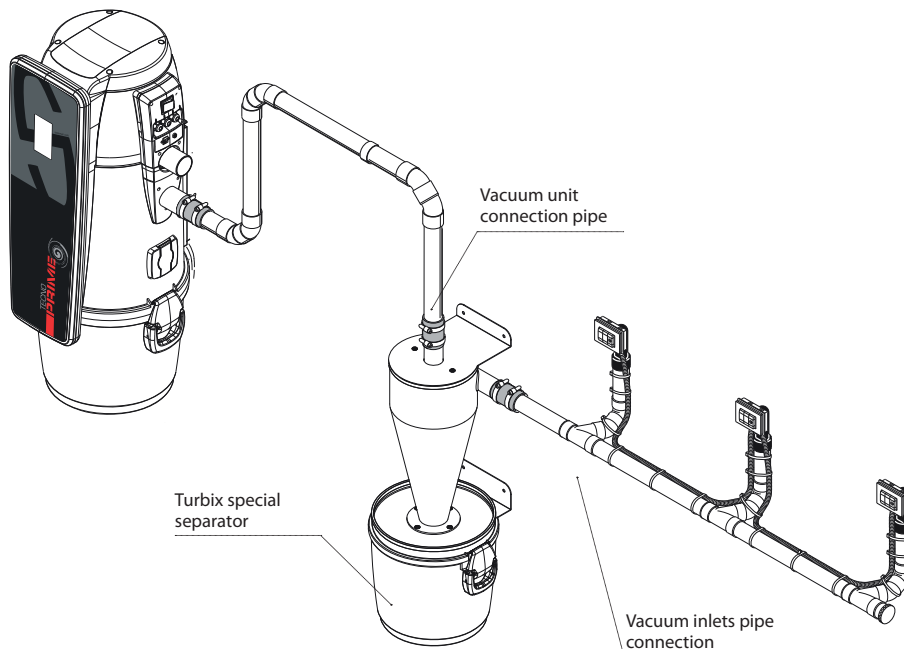



SECTION Turbix Big/Big XL

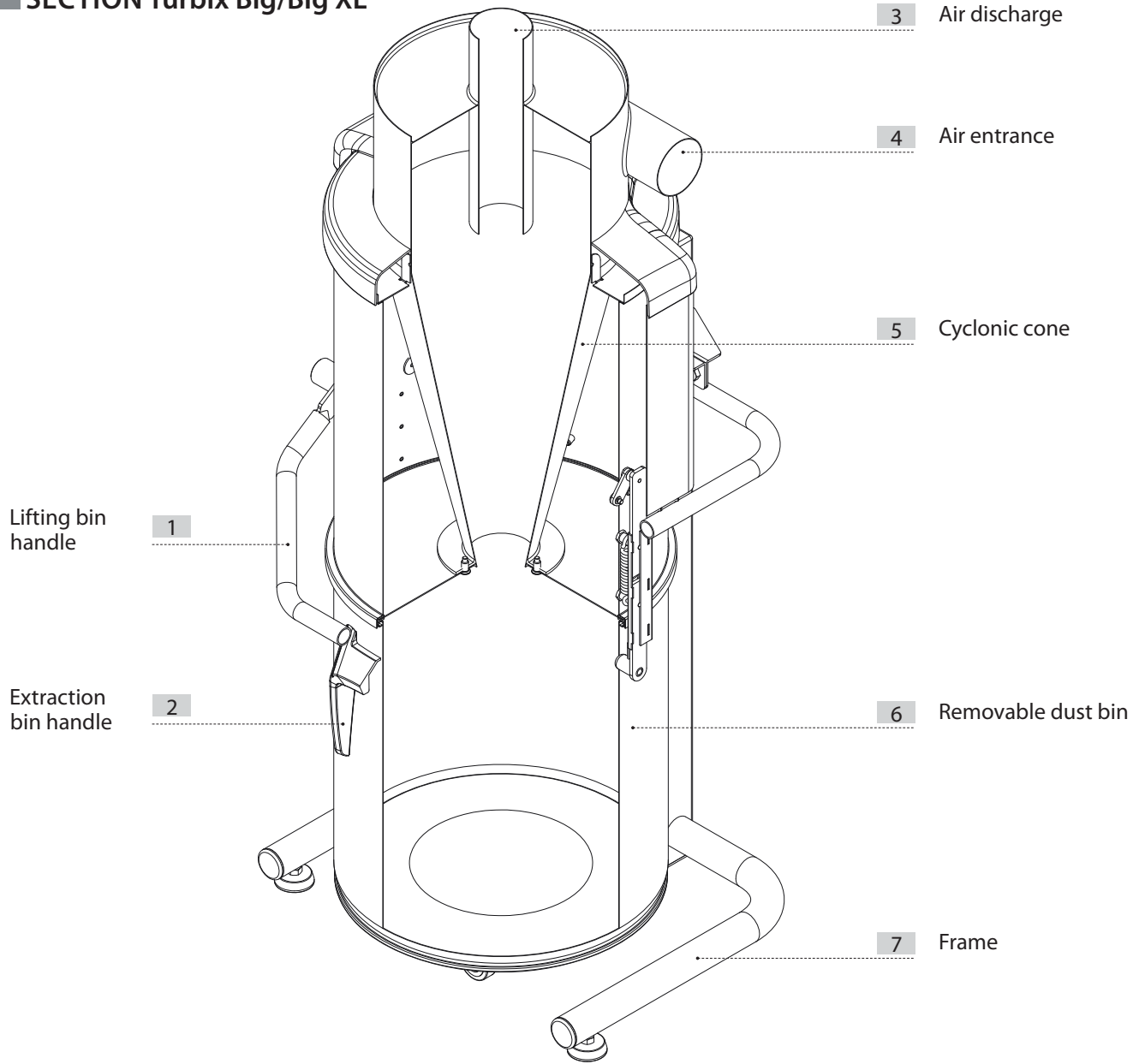

Turbix Big separator has a large capacity dust bin.

TURBIX

MEASUREMENTS AND TECHNICAL DATA

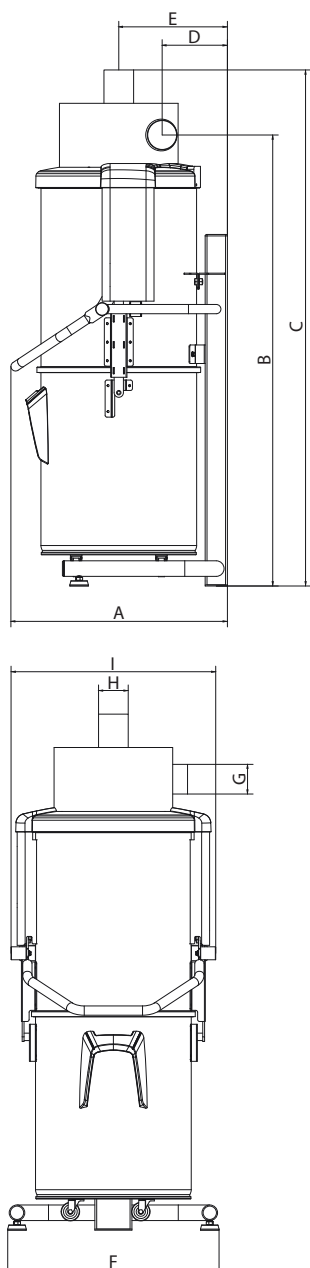

		Turbix	
		Big Turbix	Big XL Turbix
Model Article		3400.12	3400.13
Dust IN/OUT	Ø mm	80	100
Dust bin capacity	l	70	106
Weight	kg	53	70
Measurement A	mm	590	700
Measurement B	mm	1217	1415
Measurement C	mm	1395	1600
Measurement D	mm	176	200
Measurement E	mm	293	360
Measurement F	mm	570	700
Measurement G	Ø mm	80	100
Measurement H	Ø mm	80	100
Measurement I	mm	552	680

TECHNICAL FEATURES

Turbix Big dust separators are designed and produced in conformity with all current regulations and European directives, whilst taking into account functionality, power and capacity.

Main technical characteristics can be listed as follows:

- Metal cylindrical frame painted with epoxy powder
- Metal dust bin painted with epoxy powder (model Turbix Big/XL capacity 70/106 litres)
- Possible connection from the right or from the left
- Sleeves for connection to the pipe network supplied

INSTALLATION HINTS

Turbix Big cyclonic separators are connected at the end of the line that comes from the vacuum inlets before the vacuum unit (or main dust separator). The connection can be made at the end of a group of inlets, in order to make cyclonic separation only for a certain group of inlets, or it can take place just before the vacuum unit (or main dust separator), to collect all the vacuumed material.

FIXING THE SEPARATOR

Turbix Big cyclonic separator does not require special anchoring. However, it is important to check that the area for installation has the following minimum requirements, in order to be correctly and securely positioned.

- a perfectly flat, horizontal and solid surface, without cracks.
- a vibration free surface. Furthermore it is essential that there are no disconnections that could make the central unit instable

EASY BIN EMPTYING

Turbix Big cyclonic separator has a dust container with an easy opening system.

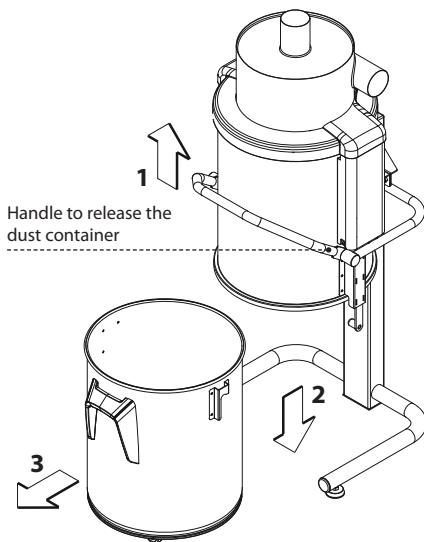

DUST CONTAINER WITH WHEELS

Thanks to its wheels, the dust container can be moved easily

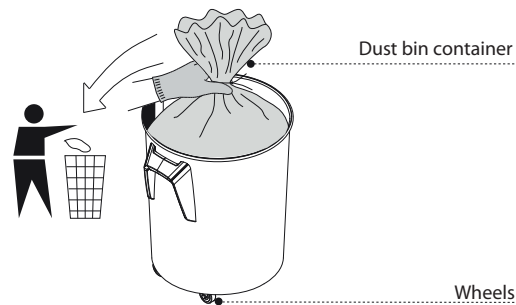

REVERSIBLE CONNECTIONS

All Turbix separators can **be connected to the pipe network from the right or from the left.** Transformation is easy and quick.

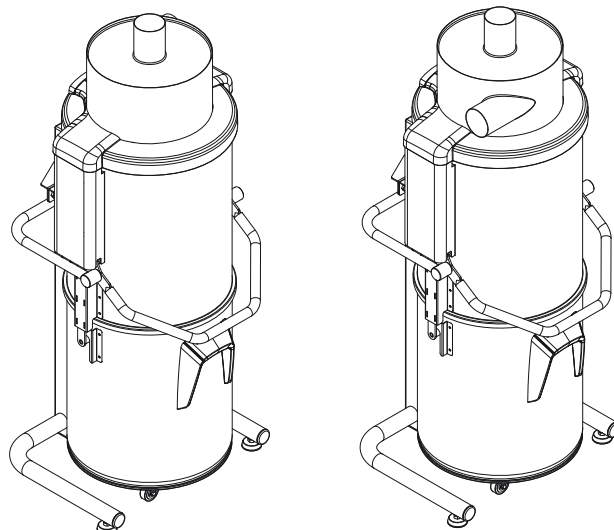

TURBIX

PIPE NETWORK CONNECTION

Turbix separators are supplied with connecting anti-vibration sleeves and clamps for the pipe network connection.

The separator must be connected to the pipe network before the vacuum unit, so that it can intercept the dust arriving from the vacuum inlets, before it reaches the vacuum unit.

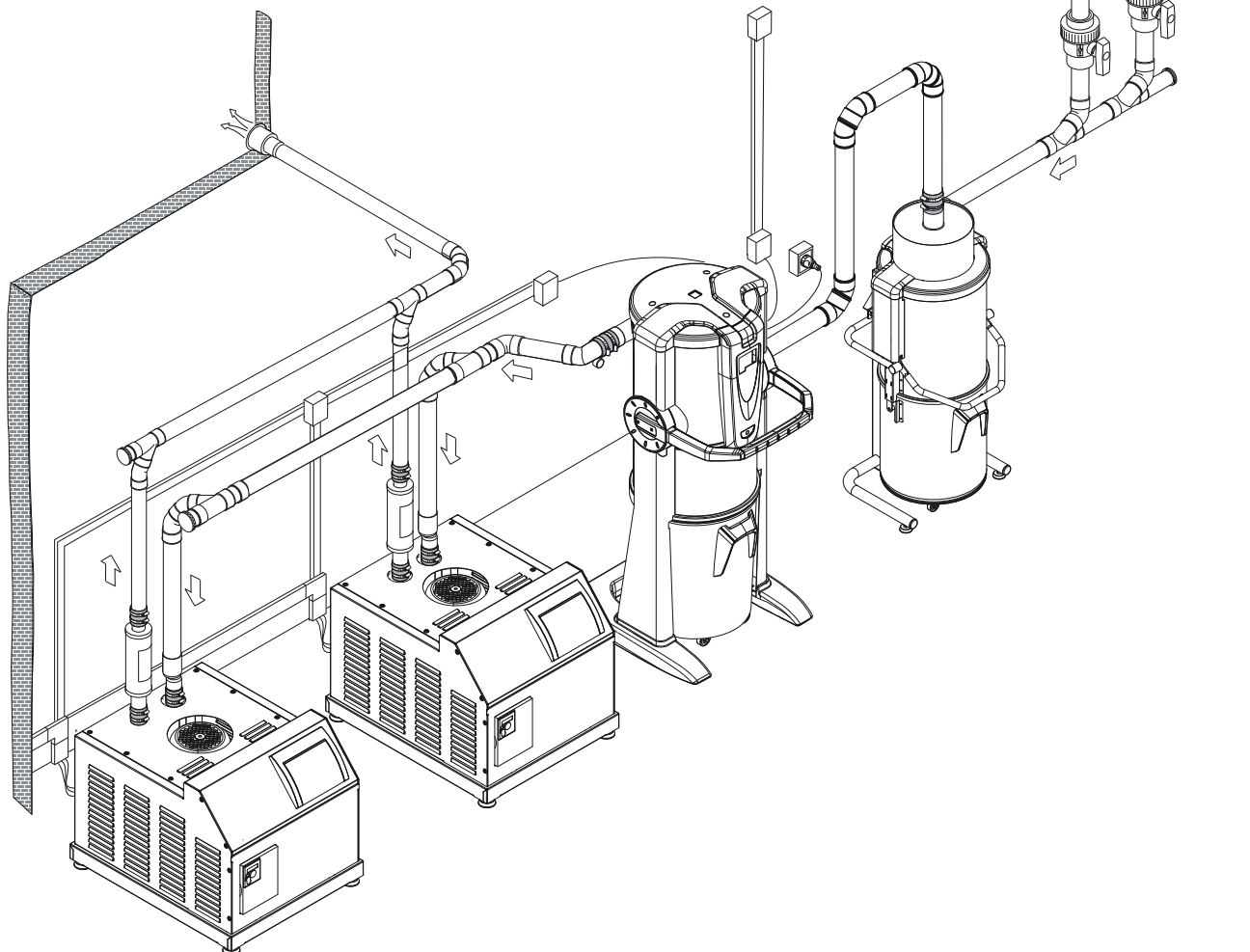

The TURBIX cyclonic separators solve many problems related to filter clogging: from aspiration of fine dust in a factory, to that of the ashes of a home fireplace.





The cyclonic separation makes it possible to drastically reduce the maintenance of the filter, increasing the autonomy of suction and improving the efficiency of the entire system.

